

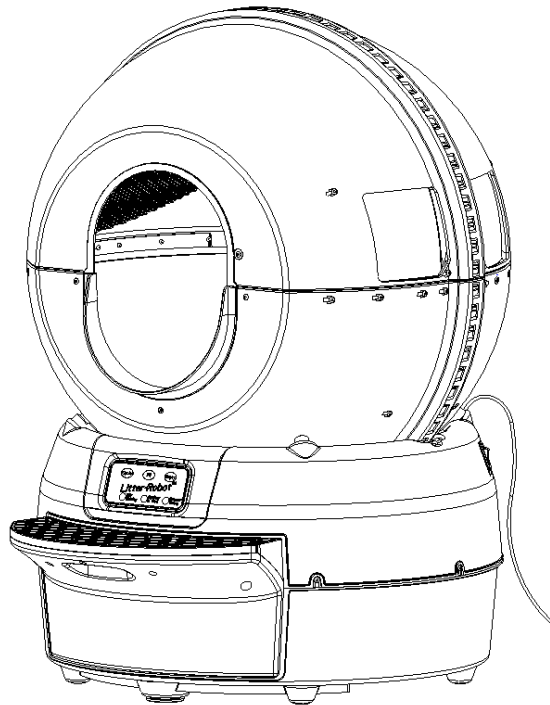

# Litter-Robot™ Manual

*The Self-Cleaning Litter Box that  
Really Works*





## Table of Contents

Important – Read This First .....	1
Introduction .....	2
Setting Up Your Litter-Robot.....	3
Getting Your Cat to Use the Litter-Robot.....	5
Control Panel.....	7
Installing Garbage Bags in the Waste Drawer...	10
Filling the Litter-Robot with Litter .....	11
How the Cat Sensor Works .....	15
Testing the Cat Sensor .....	16
Adjusting the Cat Sensor Sensitivity .....	18
Safety Features .....	21
Cleaning and Maintenance.....	24
Money Back Guarantee and Warranty.....	27
Contacting Customer Service .....	28
Frequently Asked Questions.....	29
Troubleshooting.....	34

## Important – Read This First

- **The Litter-Robot™ has been designed to be used as a self cleaning litter box for cats between 5 and 15 lbs. It is not intended for any other use.**

**The Litter-Robot is not recommended for kittens, or small cats that weigh 5 lbs or less.**

**Always be sure that each cat in your household is heavy enough to activate the Cat Sensor before you let the Litter-Robot operate in automatic mode.**

**Make sure the Litter-Robot is placed on a level firm surface. Placing the Litter-Robot on deep carpet may require adjusting the cat sensor (more sensitive).**

- Do not put anything in the Globe other than clumping cat litter. You can use water and soap to clean the Globe.
- Do not force your cat into the Litter-Robot.
- Do not sit on, or place anything on the Litter-Robot.
- Do not remove the Globe while it is rotating.
- Do not wet or submerge the Base.

## Introduction

Thank you for purchasing the Litter-Robot™, the self-cleaning litter box that really works!

At Automated Pet Care Products, Inc. we aim to develop pet products that make your life easier. This manual will help you get the most out of your Litter-Robot. We will guide you through the setup process, as well as provide you with useful tips and advice for getting your cat acclimated to its new self-cleaning litter box.

Try the Litter-Robot in your home for 60 days. If you or your cats are not completely satisfied, for any reason, simply return the Litter-Robot within 60 days for a refund of the purchase price (does not include original shipping cost). If you need assistance during your trial period, please call us at the toll-free number or e-mail us at [help@litter-robot.com](mailto:help@litter-robot.com).

Enjoy your Litter-Robot, enjoy your freedom.

Please contact us if you have any questions, comments or suggestions.

Brad Baxter  
President  
Automated Pet Care Products, Inc.

## Setting Up Your Litter-Robot

1. Place the Litter-Robot in the same location as the old litter box, if possible. Make sure the Litter-Robot is placed on a level, firm surface.
2. Put the Globe on the Base with the Cat Entry opening facing the front as shown in the picture below. Make sure that the track on the Globe engages with the gear in the Base unit.

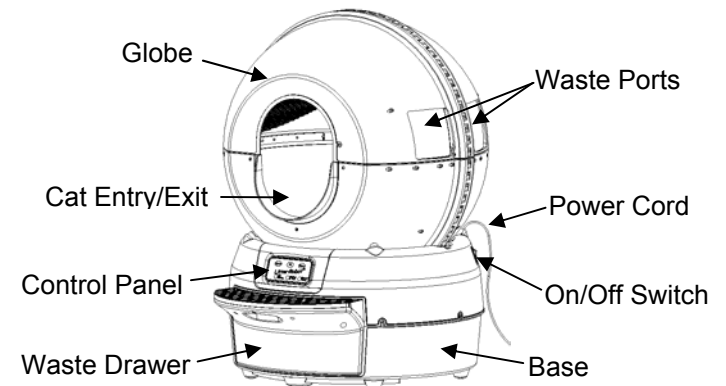

3. Plug the small connector from the AC adapter into the socket in the back of the Base unit. Next, plug the main power cord into a wall outlet. Press the On/Off Switch - the Litter-Robot will perform an initialization cycle (this takes about 3 minutes). After completing the cycle, the Globe should be in the "home" position with the green light on ("OK/Waiting" on the Control Panel). At this point, the Litter-Robot is ready to be filled with litter.

### Note

Please keep in mind that the Cat Re-entry Protection is active during the initialization. If your cat is eager to check out her new litter box, you may want to prevent her from stepping on the drawer during this phase to allow the initialization cycle to be completed without interruption.

To ensure that your cats ease into this new litter box experience, you can turn the Litter-Robot Off for a few days to give your cats sufficient time to get accustomed to the Litter-Robot.

The next section contains some proven ideas to get your cats to use their new self-cleaning litter box.

## Getting Your Cat to Use the Litter-Robot

Most likely, your cat will quickly adapt to the Litter-Robot. We recommend the following steps for the best results of getting your cat acclimated:

- Place the Litter-Robot in the same location as the current litter pan. Set up the Litter-Robot according to the instructions and turn it off after the initialization cycle has been completed. Give your cats a day or so to explore the Litter-Robot. If your cats show no interest, you can entice them to approach the Litter-Robot by using some catnip or their favorite treat.
- After your cats are at ease with the Litter-Robot you can fill the Litter-Robot with litter. Fill the Litter-Robot with clean litter according to the instructions (see next section of this manual), and then add a scoop of litter from the old litter pan. This provides a familiar scent to the cat.
- Once you notice that your cat has used the Litter-Robot, you can cycle the unit manually by simply turning the unit on. If the cats are present, it will give them a chance to observe the motion and become familiar with the sound of the Litter-Robot while you are present to reassure them. Turn the unit off again after the cleaning cycle has completed (the Litter-Robot should be in the home position). We recommend that you no longer clean the old litter pan once the Litter-Robot has been used by your cats.

- If your cats are not using the Litter-Robot within a few days, continue using the old brand of litter in the old litter box, and let it go as long as possible without cleaning it. Cats prefer a clean litter box and a dirty litter pan might persuade them to use the clean Litter-Robot. You can also consider replacing the litter in the Litter-Robot with a kind of litter specifically formulated for litter box training.
- Once your cats are consistently using the Litter-Robot, you can turn the unit on and let it operate in the unattended automatic mode. You can now remove the old litter box.

*Congratulations, you have successfully introduced your cats to the Litter-Robot. Enjoy your freedom from litter box scooping!*

## Control Panel



### 1. "Cycle" Button

Pressing the "Cycle" button starts the Litter-Robot cleaning cycle. To stop the cycle, press any button on the Control Panel. Press "Cycle" once again to resume the cleaning cycle.

If you stopped the Globe during the cleaning cycle, pressing "Fill" or "Empty" will return the Globe to the home position.

### 2. "Fill" Button

Pressing the "Fill" button on the Control Panel starts a counter-clockwise rotation of the Globe to bring the waste ports to the top. This position is convenient for filling the Litter-Robot with litter.

Please see the section "Filling the Litter-Robot with Litter" for details.

3. **“Empty” Button**

The “Empty” cycle removes most litter from the Globe, bypassing the sifting screen. This cycle is convenient for removing the old litter prior to cleaning the interior of the Globe.

You can read the details about removing litter in the section “Cleaning and Maintenance”.

4. **Green Light (“OK/Waiting”)**

This light indicates that the unit is OK and that the Litter-Robot is ready for your cat.

5. **Yellow Light (“Cycling/In Use”)**

The Litter-Robot is cycling (Cleaning cycle, Fill cycle, or Empty cycle).

6. **Red Light (“Sensor/Timing”)**

The red light indicates that the Cat Sensor has been activated and the Litter-Robot is going through the seven minute count-down before starting the cleaning cycle. If the red light is flashing, an error has occurred, please see the Troubleshooting section for steps to take to solve this problem.

**NOTE**

If the Cat Sensor is tripped again within the seven minutes of the count-down, the count-down timer resets. The Globe will not turn until another seven minutes have elapsed. You can cancel the “cat detected” seven minute count-down (red light is on) at any time by pressing any of the buttons on the Control Panel.

**Control Panel Lockout Feature**

The Control Panel Lockout Feature prevents children (or your pet) from pressing the buttons and cycling the unit unnecessarily. However, the Litter-Robot will continue to function normally in the automatic mode.

To lock the Control Panel:

- Hold down any button on the Control Panel for ten seconds.

To unlock the Control Panel:

- Hold down any button on the Control Panel for ten seconds.

## Installing Garbage Bags in the Waste Drawer

Your Litter-Robot is shipped with a 13 gallon trash bag already installed in the waste drawer - two extra trash bags have been provided. The standard 13 gallon bags were chosen for their size, availability, and low cost. Standard 8 gallon trash bags also work well.

To install a 13 gallon trash bag in the waste drawer, open the bag and push the rim of the bag into the (5) rubber grommets. Make sure that the opening of the bag is taut and that it covers the entire perimeter between the (5) grommets.

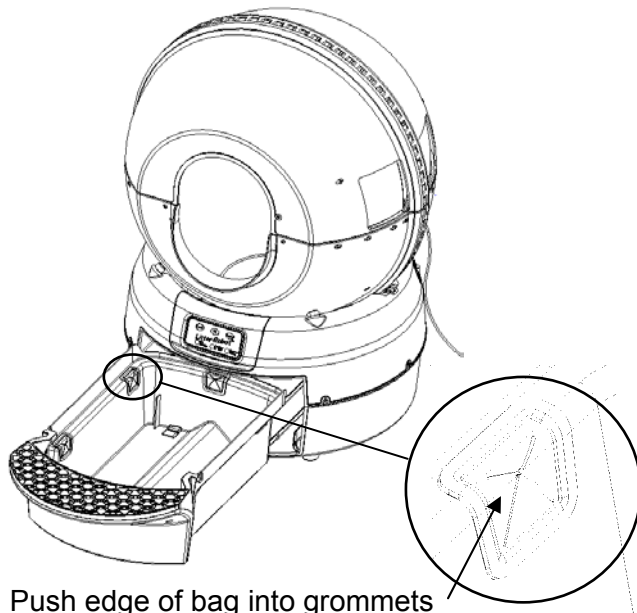

Push edge of bag into grommets

## Filling the Litter-Robot with Litter

The Litter-Robot litter sifting system requires a clumping type litter to work properly. The Litter-Robot is also compatible with the following biodegradable clumping litters: World's Best Cat Litter, and Swheat Scoop. Litter Pearls, and crystals can also be used with the Litter Robot. Litters that do not work in the Litter-Robot are the strictly absorbent, non-clumping litters, newspaper based litters, and Feline Pine Absorbent Pellets. If you are using a litter alternative not listed here, you can contact us at [help@litter-robot.com](mailto:help@litter-robot.com) to make sure you are using a compatible litter.

If you are filling the Litter-Robot for the first time we recommend that you do not switch litter brands at this time. Your cats need to get used to this new litter box and introducing a new kind of litter may increase their level of apprehension. However, if you are currently using a non-clumping litter you will need to switch to a clumping style litter.

To fill the Litter-Robot with litter, follow these steps:

1. Make sure the Litter-Robot is turned on and that the Globe is in the home position.
2. Litter can be added to the Globe in two ways:
  - Filling through the entry/exit opening (Step 3)
  - Filling through the square waste ports (Step 4)

### 3. Filling through the entrance opening

Make sure that the Globe is in the home position. Scoop approximately 9 lbs or 1½ gallons of litter (whichever is less) into the Globe through the cat entry/exit opening.

With the Globe in the home position, the litter level should not be higher than the 'Fill Line' ring (see figure below).

After adding litter to the Litter-Robot you can start a cleaning cycle by pressing the "Cycle" button on the Control Panel. Any excess litter will be dumped into the waste drawer. At the end of the cycle the litter bed will be leveled.

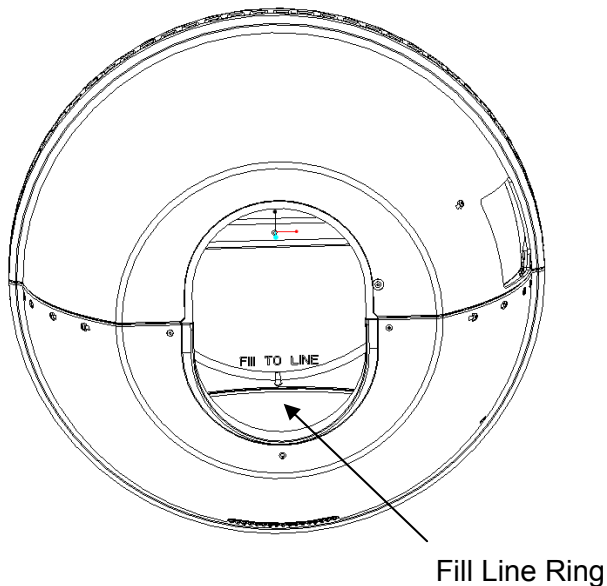

### 4. Filling through the waste ports (square holes)

First, make sure that the Globe is in the home position. Look through the Cat Entry opening and locate the ribbed handle of the Internal Guard inside the Globe, on the right. Grab this handle and rotate it upward (clockwise) until it snaps into a horizontal and locked position (see figure). Note that the pin on the opposite side of the globe should be locked behind the spring as shown below.

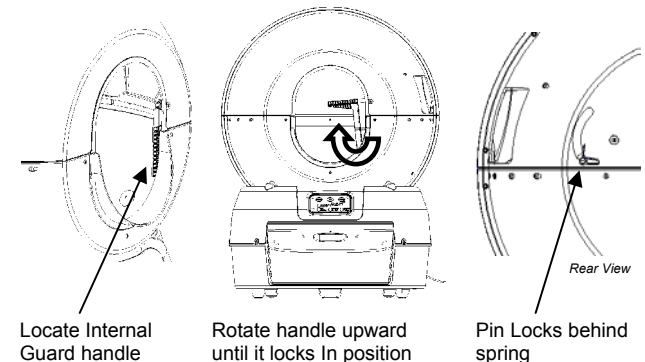

Next, press the "Fill" button on the Control Panel. This starts the Globe's rotation, bringing the waste ports to the top - a position convenient for filling.

Pour approximately 9 lbs or 1½ gallons of litter (whichever is less) through the square waste ports in the Globe. If you over-fill, the excess litter will be expelled during the first few cleaning cycles.

Note that you may want to use a towel to cover the cat entry/exit opening when filling through the waste ports as it will help reduce dust kicked up during the filling process.



After pouring litter in the Globe through the waste ports, pressing any button on the Control Panel will return the Globe to the home position.

Next, grab the handle of the Internal Guard and rotate it downward (counter-clockwise). This closes the Internal Guard. The square waste ports are now covered by the Internal Guard.

When the Globe is in the home position, the litter bed should be level and not higher than the fill line. If you over-filled, the excess litter may be expelled into the drawer during the first few clean cycles.

5. If this is the first time you filled the Litter-Robot and are trying to get your cats acclimated, you can pour a cup of used litter from the old litter box on top of the new litter in the Litter-Robot. This will provide a familiar scent for your cat. See the section "Getting Your Cat to Use the Litter-Robot" for more tips.

#### **NOTE**

During the first few days of operation the plastic Globe may exhibit a high degree of static charge. Litter will cling to all interior surfaces of the Globe. Clinging litter will eventually be released, but not necessarily at an ideal moment causing some granules to bounce out through the waste ports or the entrance opening during the clean cycle. The static cling should subside within a few cycles.



## **How the Cat Sensor Works**

The Litter-Robot Cat Sensor is a weight sensitive switch that detects your cat entering or exiting the Globe.

**Your cat must be at least five (5) lbs for the sensor to work. Do not use the Litter-Robot with kittens or cats that weigh less than five lbs.**

**Always be sure that each cat in your household is heavy enough to activate the Cat Sensor before you let the Litter-Robot operate in automatic mode.**

**Make sure the Litter-Robot is placed on a level firm surface. Placing the Litter-Robot on deep carpet may require adjusting the cat sensor (more sensitive).**

A seven minute count-down is started when the cat leaves the Globe. At the end of the count-down the Litter-Robot will start its cleaning cycle. Any subsequent tripping of the Cat Sensor starts a new seven minute count-down, preventing the Globe from rotating with your cat inside.

#### **Caution:**

**Please make sure that your smallest cat weighs at least 5 lbs before operating the Litter-Robot in the unattended automatic mode. Your cat must weigh at least 5 lbs to trip the Cat Sensor.**

## Testing the Cat Sensor

1. First, ensure that the Litter-Robot contains the right amount of litter. The maximum litter level is about 2 inches below the lower rim of the entry opening.
2. Make sure that the green light on the Litter-Robot Control Panel is on ("OK/Waiting").



3. If the red light is on ("Sensor/Timing"), push any of the buttons (Cycle, Fill, or Empty). This resets the unit and the green light should come on ("OK/Waiting"). Next, proceed to Step 4 of this Testing procedure.

If the red light stays on ("Sensor/Timing"), the Cat Sensor is too sensitive and needs to be adjusted.



To adjust the sensitivity of the Cat Sensor, see the next section: "Adjusting the Cat Sensor Sensitivity".

4. With the green light on ("OK/Waiting"), gently press down on the step with your hand until you sense a slight displacement or tilt, then release (see figures below). This should activate the Cat Sensor, as indicated by the red light ("Sensor/Timing"). The applied force represents your cat stepping on the drawer. If the effort required to trip the Cat Sensor is considerable, or you have noticed the sensor is not activating when your cat enters the Litter-Robot, then the cat sensor is not sensitive enough and needs to be adjusted. Skip Step 5 and go to the section that explains how to make these adjustments.

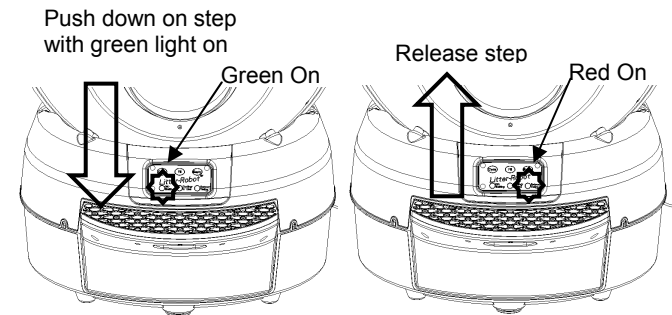

5. Now push any of the three buttons on the Control Panel to reset the unit. If the green light comes back on ("OK/Waiting"), the Cat Sensor is working properly and you have successfully completed the Sensor Test.

If the red light is still on ("Sensor/Timing"), the Cat Sensor is too sensitive and needs to be adjusted. The following section shows how to do this.

## Adjusting the Cat Sensor Sensitivity

**Note: The cat sensor is set at the factory for optimal performance for most cats. Adjustment should not normally be necessary.**

1. Make sure that the Globe contains the desired amount of litter before adjusting the sensor sensitivity. The maximum litter level should not substantially exceed the fill line in the liner.
2. Remove the Globe for easier access to the Cat Sensor Switch. It may also help to remove the waste drawer from the Base unit.
3. Slightly lift the Base unit and locate the Rotatable Foot at the front and center of the Base (see figure).

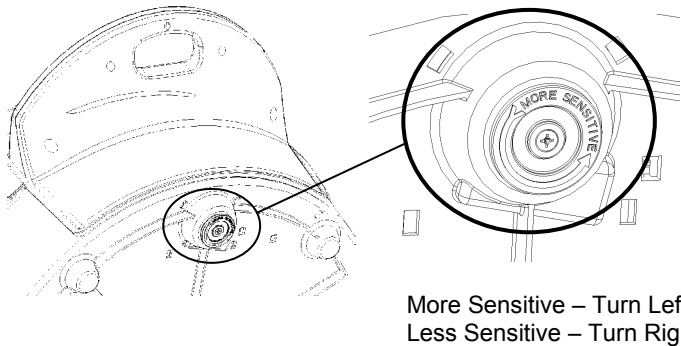

## 4. TO DECREASE THE SENSOR SENSITIVITY

To decrease the sensor sensitivity, lift the front of the Base unit and rotate the Rotatable Foot to the right (about 1 turn at a time – see figure).

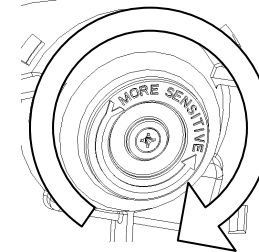

## 5. TO INCREASE THE SENSOR SENSITIVITY

To increase the sensor sensitivity, lift the front of the Base unit and rotate the Rotatable Foot to the left (about 1 turn at a time – see figure).

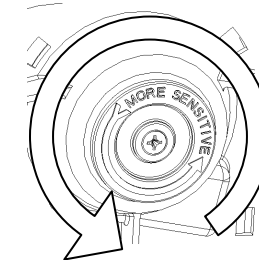

6. Next, if it was removed earlier, slide the waste drawer back into the Base unit and place the Globe back on top of the Base. Now, test the function of the Cat Sensor again.

If the red light stays on after attempting to reset the unit, the Cat Sensor is too sensitive.



If red light does not come on when your cat enters the Globe, the Cat Sensor is not sensitive enough.

7. The Cat Sensor may have to be re-adjusted several times by rotating the Foot in increments of 1 to 2 turns before the desired sensitivity is achieved.

**Note: The cat sensor is set at the factory for optimal performance for most cats. Adjustment should not normally be necessary.**

**Make sure the Litter-Robot is placed on a level firm surface. Placing the Litter-Robot on deep carpet may require adjusting the cat sensor (more sensitive).**

**If you need any help with adjusting the Cat Sensor sensitivity, please call Customer Service, toll-free, at 1-877-250-7729.**



## **Safety Features**

### **Cat Re-Entry Protection Mode**

If the Cat Sensor detects that your cat is trying to enter the Litter-Robot during a cleaning cycle the Globe will stop rotating. The Litter-Robot then waits for 15 seconds before attempting to resume the clean cycle.

### **Internal Guard**

The Litter-Robot Globe has an Internal Guard that covers the waste ports. The purpose of the Internal Guard is to prevent cats from entering the Globe through the waste ports. It also prevents litter from getting kicked out.

During the cleaning cycle, just before the Globe reaches the "dump" position, a mechanism moves the Internal Guard out of the way to open the waste ports. When the Litter-Robot Globe starts rotating back to the home position, the Internal Guard automatically closes, covering the waste ports again.

### **Anti-Pinch Safety Feature**

The Litter-Robot comes equipped with an anti-pinch feature to make the Litter-Robot extra safe for your cat. If a potential pinch condition is detected, the Globe automatically stops and then reverses direction for approximately 2 seconds.

Anti Pinch Line – Do Not Attempt to Remove

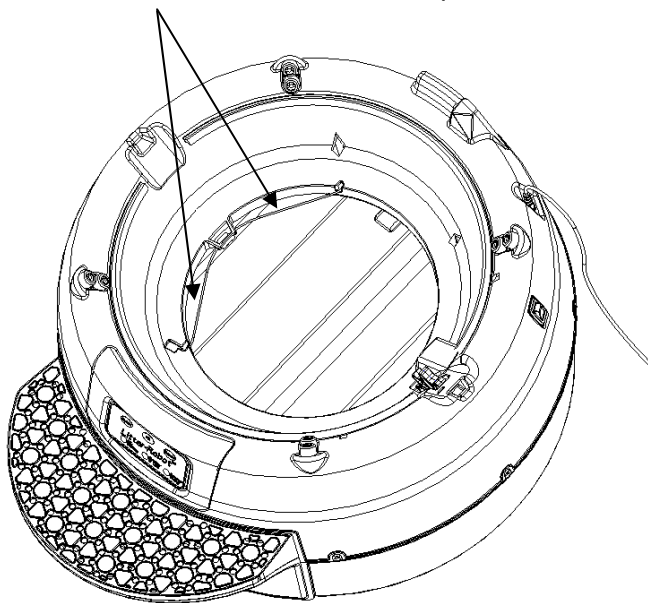

### **Automatic Shut-Off**

If the Globe becomes jammed, the motor will stop and all three lights on the Control Panel will start blinking at a rate of twice per second. To reset the unit, follow these steps:

1. Turn off unit and unplug the power cord
2. Remove the obstruction
3. Reposition the Globe in the home position
4. Plug the power cord back in and turn on. The Litter-Robot will perform an initialization cycle. Please keep in mind that the Cat Re-entry Protection is active during the initialization.

If this condition persists, please call Customer Service, toll-free, at 1-877-250-7729.

## Cleaning and Maintenance

The Litter-Robot requires no special maintenance. We recommend that you do not lubricate the four plastic 'glide buttons' on the Base unit. Lubricating these glide buttons will cause dirt to build up.

Before you clean the Litter-Robot please make sure that you remove all litter from the Globe - wet litter turns into messy clay.

### Emptying the Litter-Robot

Look through the Cat Entry opening and locate the ribbed handle of the Internal Guard on the right, inside the Globe. Rotate this handle upward (clockwise) to lock the Internal Guard in the "open" position (see figure). The Internal Guard is locked when the handle snaps into a horizontal position. The waste ports on the right side of the Globe are now open. Note that the pin on the opposite side of the globe should be locked behind the spring as shown below.

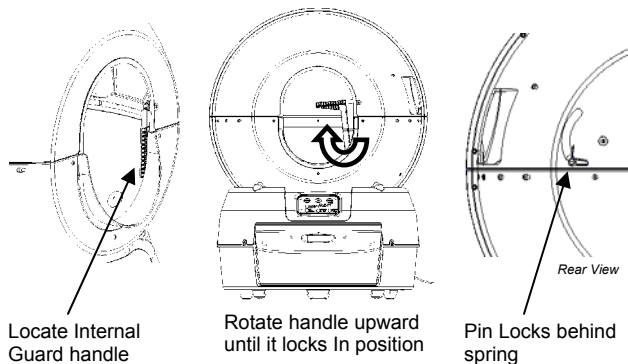

Press the "Empty" button to rotate the globe to the discharge position, with the waste ports directed into the drawer. The Litter-Robot Globe rotates clockwise to dump the litter into the waste drawer. Press any button to stop the rotation if you want to interrupt the Empty cycle. After the litter has dumped into the waste drawer, you can press any button on the Control Panel to return the Globe to the home position.

If some litter remains in the Globe, you may want to sweep the remainder out with a brush.

### Cleaning the Globe

After removing all litter from the Globe, clean the Globe with water and a mild soap. There are no electronic components in the Globe which can be damaged by soap and water. If the Globe has become extremely dirty, it can be soaked or cleaned with a water hose. Be sure that the Globe is completely dry before returning it to the Base.

For a quick touchup, you can use a disposable wipe (such as Lysol or Clorox) to wipe the inside and upper half of the Globe. This can be done without removing the litter. The Litter-Robot can be used immediately after this touch-up because drying is almost instantaneous.

### Cleaning the Waste Drawer

The drawer can easily be removed and cleaned with soap and water.

### Cleaning the Base

**Never submerge or soak the Base.** The Base contains the Cat Sensor and electronics. You can wipe the surfaces of the Base with a cloth dampened with a disinfectant.

### Carbon Filter

The Litter-Robot comes equipped with a flexible carbon filter pad for absorbing odors in the drawer. The carbon filter can be easily removed and replaced when cleaning the drawer. The carbon filter is not required and replacement frequency is based on personal preference, however one filter should last a few months under normal use. Replacement filter kits (3 filters in a kit) can be ordered from customer service at 1-877-250-7729.

### Base Seal

The Litter-Robot also comes equipped with a brush-type seal which helps to contain odors within the drawer/base. Replacement seals can also be ordered from customer service if needed at 1-877-250-7729.

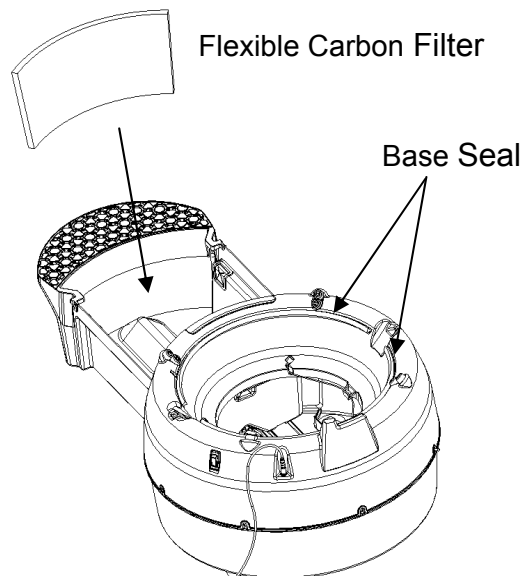

### **Money Back Guarantee and Warranty**

If you or your cat are not completely satisfied with the Litter-Robot, just return the unit to us within 60 days for a refund (less the original shipping cost).

**Please note that if you have purchased your Litter-Robot through a source other than Automated Pet Care Products, Inc., you must coordinate the return with that source and according to their product return policy.**

If you have purchased directly from Automated Pet Care Products, Inc., please contact us at 1-877-250-7729 to obtain an RMA number. You can also e-mail us at [returns@litter-robot.com](mailto:returns@litter-robot.com). Shipments without an RMA number cannot be accepted. Please also refer to the Return Instructions flyer.

Please make sure the Litter-Robot is cleaned and carefully packaged (the original packing materials are best) in order to avoid damage in shipment. The Return Instructions flyer shows a packaging diagram for the Litter-Robot.

### Warranty

Your Litter-Robot is covered by a full warranty for 18 months, starting from the date of shipment regardless of where purchased. This warranty covers all parts, labor, and shipping costs within the lower 48 states.

Customers in Alaska, Hawaii and Puerto Rico as well as APO and FPO shipments may incur additional shipping costs.



## Contacting Customer Service

If you have any questions, concerns or need assistance, contact Automated Pet Care Products, Inc.; we'll be glad to help.

[help@litter-robot.com](mailto:help@litter-robot.com)

Toll-free: 1-877-250-7729

M – F: 10 AM – 10 PM Eastern

You can also write to us at:

Automated Pet Care Products, Inc.  
40 W. Howard  
Suite B-5  
Pontiac, MI 48342

If repairs are necessary, call or email us to obtain an RMA number prior to returning your Litter-Robot.



## Frequently Asked Questions

### Will my cat actually go inside the Globe?

Cats are generally curious and will investigate any new object. Cats that are already used to a covered litter box may be quicker to investigate. We recommend that the Litter-Robot be placed in the same location where the old litter box used to be. The old litter box can be left near the Litter-Robot for a short time. Take a cup of litter from the old litter box and add it to the clean litter in the Litter-Robot. The scent will be familiar, and the cat will be inclined to investigate. Once your cat has ventured inside and feels the litter under its paws, it will know what to do. Please read the section "Getting Your Cat to Use Litter-Robot" in this manual.

### Can kittens use the Litter-Robot?

We do not recommend that kittens or cats weighing 5 lbs or less use the Litter-Robot in the unattended automatic mode. Their low weight may not activate the Cat Sensor. Cats should be at least 5 lbs before using the Litter-Robot in the automatic mode.

**CAUTION: Leave the Litter-Robot turned off and only start the cleaning cycle manually (see "Getting Your Cat to use the Litter-Robot") until you are sure that all cats in the household are heavy enough to activate the Cat Sensor.**



### **What if my cat won't use the Litter-Robot?**

If you and your cat are not completely satisfied, just return your Litter-Robot within 60 days of purchase for a refund of the purchase price (less the original shipping cost). Please contact Customer Service to request a Return Authorization (RMA) number. Return shipments without an RMA number cannot be accepted.

### **What happens if my cat tries to enter the Globe while it is rotating?**

The Cat Sensor will detect the presence of your cat and turn off the motor. The Litter-Robot pauses 15 seconds before resuming the clean cycle.

### **Are there any rakes, or wires inside the Globe?**

No, the Globe does not contain any rakes or wires that could hurt or harm your cat. The Litter-Robot was designed with your cat's safety in mind.

### **Are the electronics or power source dangerous to my cat?**

No, the Litter-Robot operates on a safe 12 Volts using an adapter very similar to the ones you may have at home for a clock radio, or for charging your cell phone. All electrical components are located in the Base, away from where the cat could reach them. There are no electrical components inside the Globe.



### **Will the Globe turn while my cat is inside?**

No, the Globe will not turn while your cat is inside. The Cat Sensor is tripped each time a cat enters, or re-enters the Globe, resetting the count-down timer to prevent the cleaning cycle from starting for another seven minutes.

### **What happens if the Globe jams?**

If the Globe jams or an excessive load condition occurs the motor is turned off automatically. In addition, the Litter-Robot is equipped with an anti-pinch safety device.

### **Does the Litter-Robot require special litter?**

No, the Litter-Robot does not require special litter. In fact, the Litter-Robot works just fine with any clumping type litter and with a variety of litter alternatives including litter beads and pearls. Litters that do not work in the Litter-Robot are the strictly absorbent, non-clumping litters, newspaper based litters and Feline Pine.

### **How much litter do I put in the Litter-Robot?**

Start with approximately 9 lbs of litter. Check that the litter does not exceed the fill line, however if there is too much litter in the globe it will be expelled into the drawer during the first few clean cycles. Since the waste clumps are removed during every cycle, there is no need to put excessive litter in the Globe.

### **Does the Litter-Robot work with Feline Pine Pellets?**

No, the Feline Pine pellets are too large to pass through the sifting screen. This prevents the litter sifting system from working properly. Feline Pine clumping is also too fluffy to effectively pass through the sifting screen.

### **How often do I need to add litter?**

Experience shows that with two small cats (approx. 8 lbs. each), litter needs to be added about once a week, and sometimes it will last longer than that. The Litter-Robot uses litter very efficiently since the patented sifting mechanism only removes the clumps.

### **Is dust a problem with the frequent rotation of the Globe and the movement of the litter?**

No, any dust is negligible since the Globe rotates very slowly.

### **How often do I need to empty the drawer?**

This depends on the number and size of your cats. For two average sized cats, twice per week is typical. For a single cat, once per week is usually sufficient.

### **How often do I have to clean the inside of the Litter-Robot Globe?**

This depends on your personal preference and your cat's behavior. However, we recommend that you clean the inside of the Globe every one to three months.

### **How do I clean the Litter-Robot exterior?**

Cleaning the Litter-Robot exterior is easy. Just remove the Globe and the drawer and give them a sponge bath, or take them outside for deep cleaning with the garden hose. All other surfaces can be wiped clean but should not be submerged.

**CAUTION: The Base of the Litter-Robot contains electrical components and is not meant to be submerged or wet.** See the "Cleaning the Litter-Robot" section for more details.

### **What are the dimensions of the Litter-Robot?**

- The fully assembled Litter Robot is 29" high, 22" wide and 24" deep.
- The waste drawer is 11" wide, 16" long and 6" deep.
- The oval shaped entry for the cat is 9" high and 6 1/2" wide.
- The litter bed area measures 14" across at maximum litter capacity.
- There is 13" to 15" of head room for the cat inside the Globe depending on the level of litter. The inside width is 20" across at the widest point, and depth is 15" front to back.

## Troubleshooting

1. All lights on the Control Panel are blinking once per second.

If the Globe cannot find the home position, all three lights on the Control Panel will blink at a rate of once per second. Make sure the Litter-Robot is on a level surface. If the condition persists, please contact Customer Service.

2. Yellow light on the Control Panel is on.

The Yellow light normally comes on to indicate that the Litter Robot is in the middle of the clean, fill, or empty cycle. If the yellow light is on and the globe is not turning, the cycle has been interrupted by the Cat Sensor. The Litter-Robot will wait 15 seconds before attempting to resume the cycle. If the Cat Sensor is continuously interrupted for more than two minutes the globe will remain stationary and the Red light will start flashing.

3. Red light ("Sensor/Timing") on the Control Panel is flashing.

This condition indicates that the Cat Sensor was triggered continuously for more than two minutes.

- a. Check to see that the Litter-Robot is on a level surface.
- b. Make sure that there is no excess litter in the Globe. The litter level should be at least two inches below the bottom rim of the cat entry opening.

- c. Test the Cat Sensor sensitivity and adjust if necessary (see the sections in this manual about the Cat Sensor).

3. Lights on the Control Panel are blinking twice per second.

If the Globe becomes jammed or if the rotation of the Globe has become obstructed or interrupted several times, the motor will stop and all three lights on the Control Panel will blink at a rate of twice per second. Follow these steps to reset the unit:

- Turn off the unit and unplug the power cord.
- Remove the obstruction.
- Reposition the Globe in the home position.
- Plug the power cord back in and turn the unit on. The Litter-Robot performs an initialization cycle.

If the condition persists, please call Customer Service, toll-free, at 1-877-250-7729.

Automated Pet Care Products, Inc.  
40 W. Howard, Suite B-5  
Pontiac, MI 48342  
Toll Free: 877-250-7729  
Fax: 248-253-1797  
[www.litter-robot.com](http://www.litter-robot.com)

Litter-Robot™ Manual Version 2008030408